



## Air Handling Unit **iZZi 402 ERV** with enthalpic exchanger

### Features

- enthalpy counterflow heat exchanger with moisture recovery,
- no condensate drainage,
- operation at negative outdoor temperatures without additional pre-heater
- the unit has a built-in bypass,
- V version with upward-facing spigots - wall or floor mounted,
- color touch panel as standard,
- energy efficient DC fans with FlowGrid (reduced noise emission),
- compact casing made of stainless steel and flap made of composite panel,
- can be retrofitted with a dedicated constant volume module (recommended especially for self-assembly),
- automatic operation based on the air quality in the house (with additional module with carbon dioxide and humidity sensor),
- PE foam insulation with excellent acoustic properties,
- convenient installation console included.

iZZi 402 ERV is a compact air handling unit with universal mounting system - in any position: under the ceiling, on the wall or on the floor. Applied enthalpy exchanger CORE ERV with innovative polymer membrane, allows to recover not only heat energy but also moisture. No outflow of condensate, flat design and convenient touch panel control allows for easy installation of the unit in places where it was previously not possible. iZZi air handling unit is also ideal for installation in apartments and houses already finished and inhabited. Quiet operation of the device, inter alia due to the use of special foam insulation and modern DC motors, makes it possible to place it in living spaces, e.g. above the suspended ceiling. The recuperator is equipped with high quality M5 class pleated filters and the whole unit is enclosed in an aesthetic casing made of stainless steel.

The air handling unit iZZi 302 ERV can be expanded with additional modules:

Constant flow module - ensuring automatic balancing of the supply and exhaust flow in the ventilation system.

CO<sub>2</sub>/hygro measuring module - enabling automatic recuperator efficiency control based on the air quality in the house.

### Equipment of iZZi series Air Handling Units:



EC fans



Control panel



Constant flow system (optional)



Built in CO<sub>2</sub> sensor (optional)



Built in humidity sensor (optional)



extensive automation



automatic by-pass 100%



universal assembly system



Antismog box antysmogowa



No condensation

Model	izzi 402 ERV		
Maximum air flow	400 m <sup>3</sup> /h at 150 Pa		
Heat recovery efficiency	Up to 85%		
Exchanger type	cross-flow counter-current		
Exchanger type	enthalpic (with moisture recovery)		
Exchanger material	plastic + polymer membrane		
Moisture recovery efficiency	Up to 65%		
Maximum power of fans	210 W		
Gears	I gear (100 m <sup>3</sup> /h at 50 Pa)	II gear (250 m <sup>3</sup> /h at 100 Pa)	III gear (400 m <sup>3</sup> /h at 150 Pa)
Energy consumption	20 W	73 W	205 W
Sound power level emitted by the housing at a distance of distance of 1 meter	31 dB(A)	39 dB(A)	45 dB(A)
Sound power level-nominal value	41 dB(A)		
Fans	radial Redicals with EC direct current motors (ebm-papst)		
Efficiency class energy efficiency class	A*		
Bypass	automatic, insulated, 100% supply air bypass		
Anti-freeze system	negative pressure, works only below -7°C		
Controller	LCD 3.2" with color touch panel		
Controller connection device	4x0.5** shielded cable (3 meters included)		
Filters	pleated class M5*** / ePM10 75%****		
Stub pipe diameter diameter	4 x Ø200 mm		
Condensate drain	no		
Degree of protection	IP 40		
Equipment insulation class	I		
Supply voltage	230V (AC), 50Hz		
Weight (with dedicated rack)	36 kg		
Dimensions (H x W x D)	700 x 600 x 600 mm		

### Dimensions:

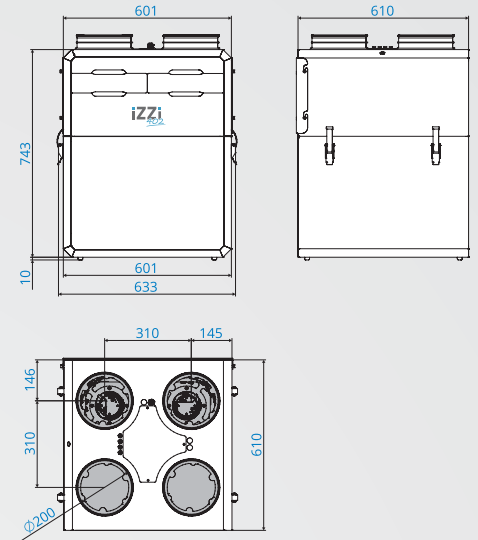

### Flow characteristics:

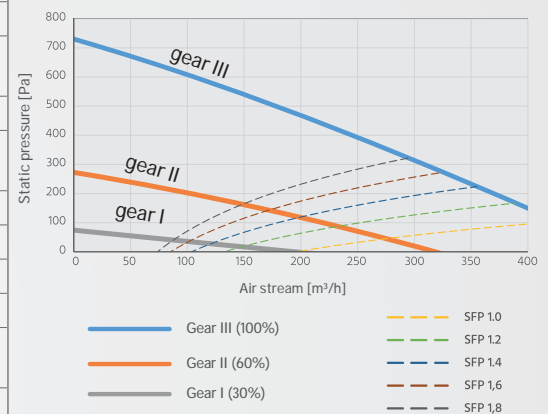

\* for moderate climates according to Directive 2009/125/EC and European Commission Regulation 1254/2014  
 \*\* over 10 m length 4x0.75 recommended (shielded)  
 \*\*\* according to EN779  
 \*\*\*\* according to ISO 16890

### The advantages of using an ERV exchanger with a polymeric membrane:

- maintaining the optimum humidity level in the house throughout the year,
- no condensate draining in the recuperator,
- less probability of freezing and need for defrosting,
- antibacterial - resistance to mould and bacteria,
- possibility to clean with water,
- long life,
- no penetration of contaminants.

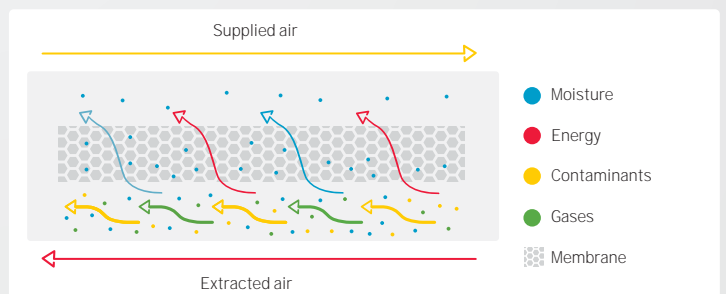

### Extensive library of operating modes and programs



automatic (optional)



schedule



ventilation



away from home



fire place



gear I



gear II



gear III



off